

**PRODUCT: SMA FEMALE TO N FEMALE PANEL MOUNT ADAPTER, 50 OHM**  
**PRODUCT CODE: E3819, Paratronic Oy**

Description	Material	Note	General information	
Contact pin	Phosphor bronze	1	Dimensions in millimeters (mm), unless otherwise specified. RoHS compliant. Directive 2015/863 with exemption 6(c) Note, finish, plating thickness in micro-inches, $\mu\text{in}$ (minimum): 1. Gold (3) over nickel (50) over copper (50) 2. Nickel (100) over copper (50)	Impedance 50 ohm Frequency range DC - 11 GHz VSWR 1.35 max Insertion loss $\leq 0.3$ dB
Insulator	PTFE	-		
Body	Brass	2		

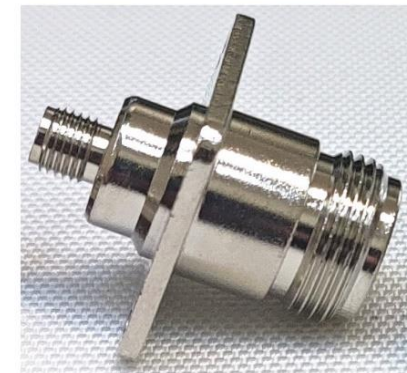
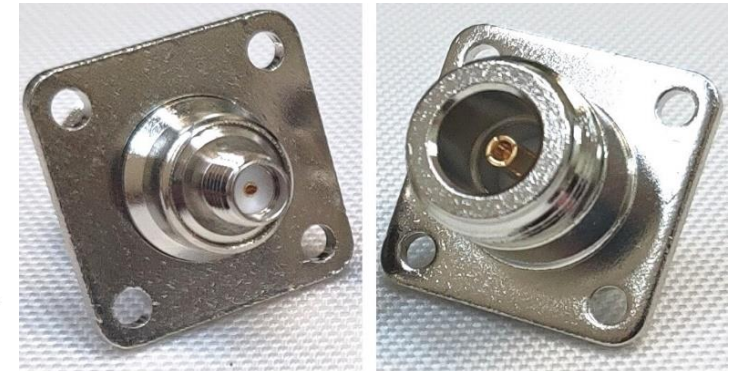
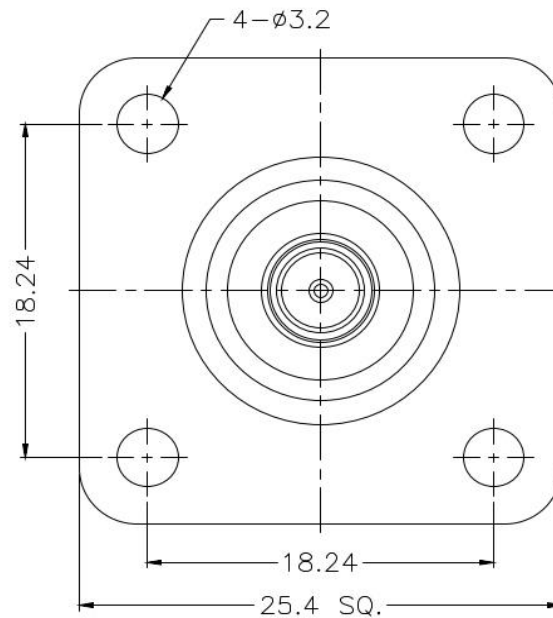
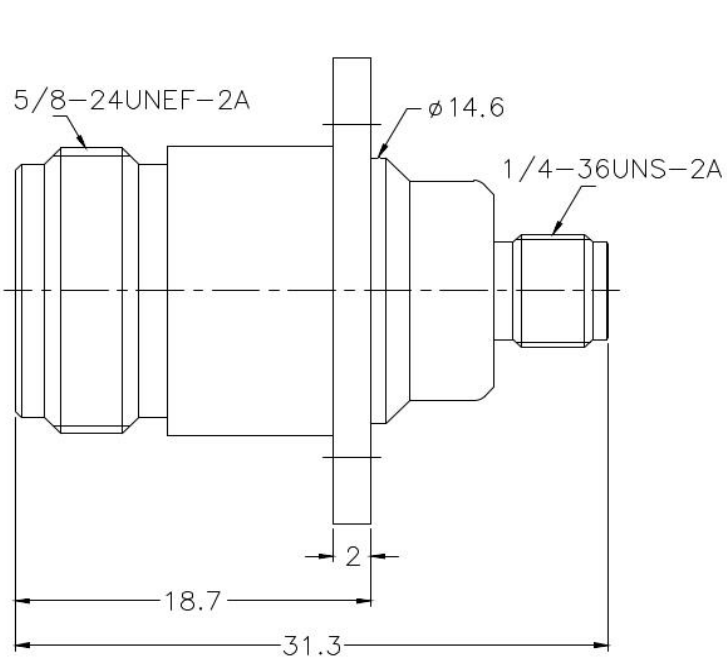

Title	Value
Drawing date	22.1.2023
Version	A
Website	<a href="http://www.paratronic.fi">www.paratronic.fi</a>